

Elevate Counter Clockwise

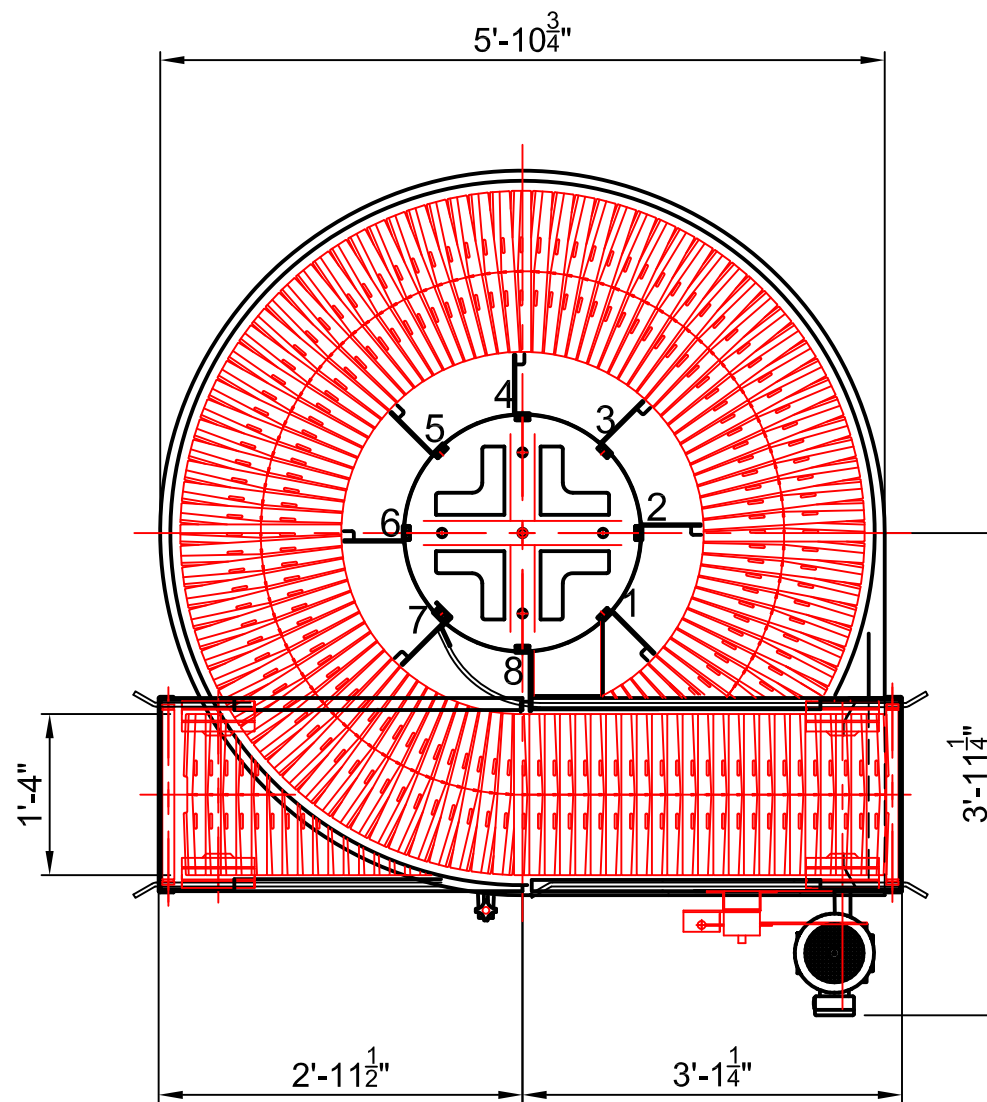

SLIM RED
3250 LBS.

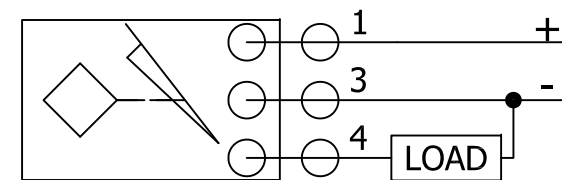

SENSOR INFORMATION

- A. TURCK # NI10-P18SK-AP6X2
- B. OUTPUT - 3 WIRE DC SENSOR
- C. VOLTAGE - 10 TO 30 VDC
- D. SENSING RANGE - 10MM
- E. OUTPUT - 24 VDC PNP

APPROVED FOR CONSTRUCTION

SIGNED: _____ DATE: _____

Brake Coil Voltage: None

Tensioner: Spring Reversible Height

REVISIONS TO THIS DRAWING WILL BE SHOWN IN RED

# Turns: 5 @ 10.08°	Finish: RAL 3003 Ryson Red
TYPE: 1300-400-A3	Speed: 120 fpm
Direction: Up/CCW	Infeed: 1'-2"
Drive Motor: 2 Hp	Outfeed: 13'-6"
Motor Current: 3.1 A	Elev. Change: 12'-4"
Motor Power: 3/60/230/460	Prox switches: 24 VDC PNP

RYSON
INTERNATIONAL, INC.
www.ryson.com

Ryson International
Show Spiral

DESIGNER WEJ	DWG NO. 102996	REV -
CHECKED -	DATE 09/01/10	SCALE NTS
		SHEET 1 of 1