

Multiple Entry & Exit Spirals

Utilize Vertical Space with Multi-level Conveying



The Ryson High Capacity and Wide Track Spirals can be configured to allow loads to enter or exit at several intermediate elevations. Ancillary induction and divert conveyors can be utilized to allow loads to enter or exit the spiral at intermediate elevations. An ideal space-saving solution for multi-tiered product flow - like pick modules.

Easy to Install: All Ryson Spirals are tested after assembly. Many, depending on diameter and configuration, are shipped in one piece, drastically reducing time and cost of installation.

Modular Design: Our unique design offers flexibility of configuration. It also adds the ability to field modify to accommodate changing future needs at a fraction of the cost of a new conveyor.

Low Maintenance: Our Spirals and components are designed for reliability, low maintenance and long life. They have an impressive up-time record reducing the total cost of ownership.

Built-in Protection: All Ryson Spirals are equipped with an automatic chain tensioning device and built-in overload protection ensuring safe and reliable operation.

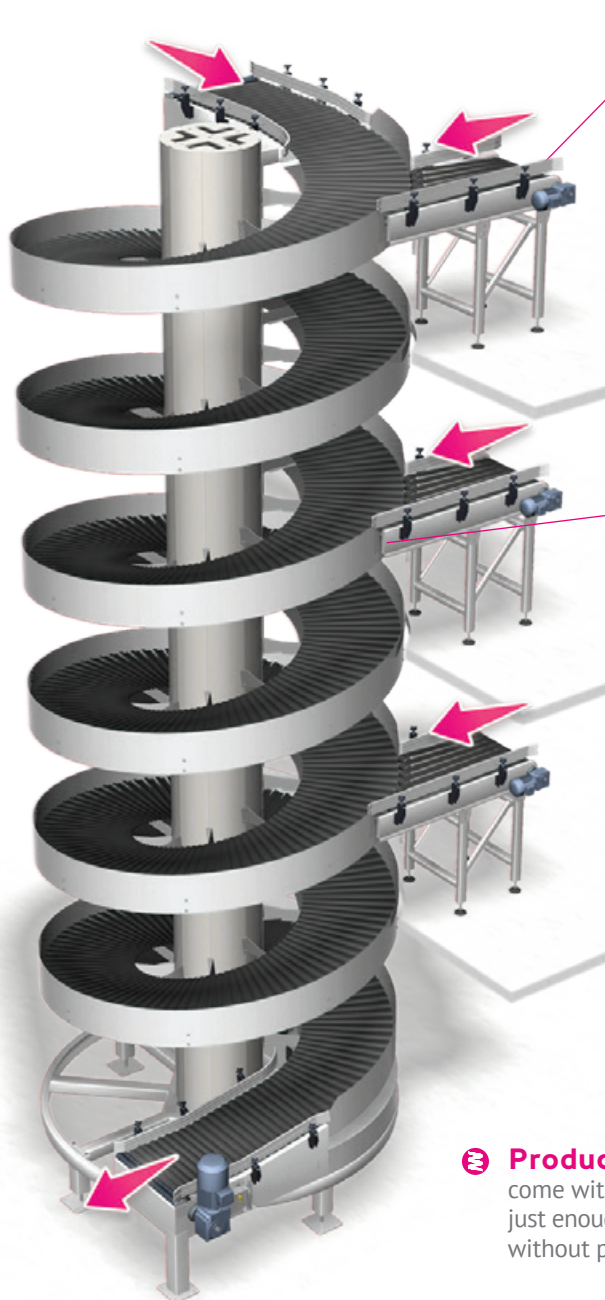

Induction:



Powered rollers introduce loads onto the spiral. They are individually adjustable to dial in a seamless induction that is gentle to the product.

Perfect Fit: These conveyors are designed to match the spiral's radius and pitch, assuring a safe and reliable product transfer.

Divert:



Our Divert Out Conveyors have a pivoting arm with a powered face belt assuring proper product orientation and gentle handling when diverting out of the spiral.

Product Grip: The Multiple Entry and Exit Spirals come with special rounded friction inserts. They provide just enough friction to prevent products from back sliding without preventing a smooth induction or divert.

Controls and Integration: Most Spirals are shipped without controls because they typically integrate with an overall conveyor control system. We do offer a number of controls and pre-wiring options. A Variable Frequency Drive (VFD) is required for proper operation of the Spirals.

Traffic Control: Integrated traffic controls are required for all Multiple Entry and Exit Spirals to prevent jamming.



Scan or Click for full details



Quick Facts:

Maximum Speed: 180 FPM
 Slat Width: 16", 24", 30", 36"
 Weight Capacity: 75 lbs/lin foot
 Total Weight: Up to 3600 lbs
 VFD Required: Yes
 Optional Controls: Yes
 Custom Options: Yes
 Color Options: RAL colors
 Incline Angle: Up to 12.5°

Configurations:

All Ryson Spiral Conveyors are available in several standard versions to accommodate a wide range of loads and applications.

- The Spiral Conveyors can be configured to go up or down, clockwise or counter-clockwise and can optionally be reversible.
- All models can be built with extended infeed or outfeed tangents, making our Spiral Conveyors an easy to fit and help simplify the most challenging of layouts.

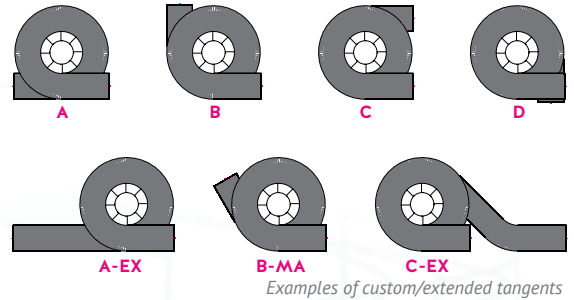
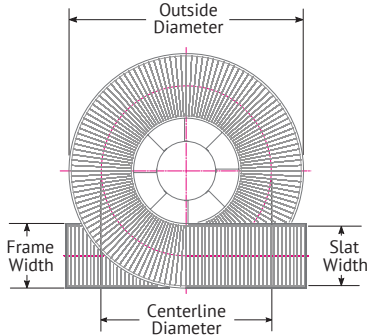

Type	Outside Diameter	Centerline Diameter	Slat Width	Frame Width
1700-400-HC	7'-3" (2200)	5'-7" (1700)	16" (400)	19" (480)
1700-600-HC	7'-11" (2400)	5'-7" (1700)	24" (600)	27" (680)
1900-600-HC	8'-6" (2600)	6'-3" (1900)	24" (600)	27" (680)
2200-760-WT	9'-11" (3010)	7'-3" (2200)	30" (760)	33" (840)
3000-900-WT	13'-0" (3950)	9'-10" (3000)	36" (900)	38" (980)

Powder Coated Carbon Steel

Part	Specifications
Frame	Coated aluminium tube with galvanized load arms
Chain configuration	Nickel plated chain, carbon steel bearings
Finish	Powder Coated in most RAL colors

Stainless Steel Hybrid (Dry)

Part	Specifications
Frame	Coated aluminium center tube zinc plated load arms
Chain configuration	Nickel plated chain, carbon steel bearings
Finish	Stainless steel base frame, legs & side guards.

Stainless Steel (Wet)

Part	Specifications
Frame	Stainless steel or coated aluminium tube depending on model. Stainless steel base frame, load arms & fasteners.
Chain configuration	Nickel plated chain with stainless steel sealed bearings
Finish	Stainless steel base frame, legs & side guards.

Typically Conveys:



Totes



Carton wrapped



Cartons

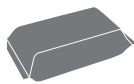

Bags



Crates



Shrink wrapped



VERTICAL CONVEYING SOLUTIONS. WORLDWIDE.

Ryson is a member of the Royal Apollo Group, established in 1847 and headquartered in the Netherlands. Ryson manufactures in USA and supports North America. We have manufacturing in Netherlands, USA, and Thailand with service operations in Netherlands, USA, Thailand, China, India, and Mexico. As one global company, we are the world's leader in Vertical Conveying!

