



The Ryson Unit Load - or - Case Spirals need less floor space than conventional conveyors and are faster and more reliable than any elevator or lift. They can convey all kinds of packaged goods in a continuous flow. Their proprietary modular design offers many features and benefits and can help lower your total cost of ownership.

Easy to Install:

Most Spirals are shipped in one piece, pre-assembled and pre-tested, drastically reducing time and cost of installation.

Modular Design:

Our unique design offers flexibility of configuration. It also adds the ability to field modify to accommodate changing future needs at a fraction of the cost of a new conveyor.

Low Maintenance:

Our Spirals and components are designed for reliability, low maintenance and long life. They have an impressive up-time record reducing the total cost of ownership.

Built-in Protection:

All Ryson Spirals are equipped with an automatic chain tensioning device and built-in overload protection ensuring safe and reliable operation.

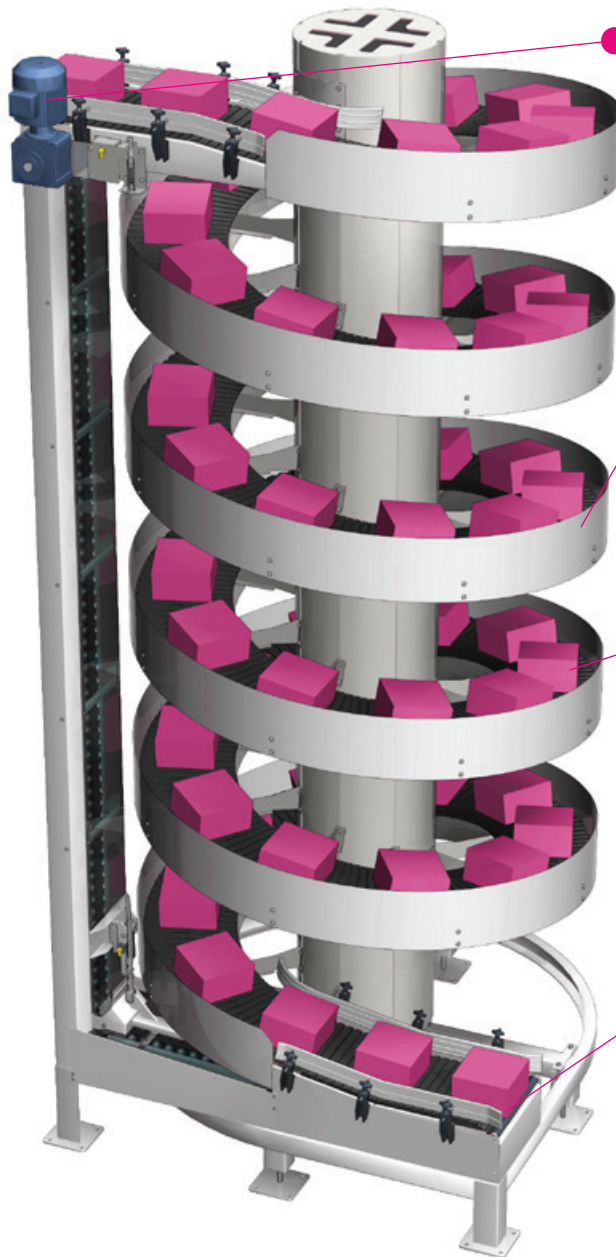

Single Drive: Our efficient rolling friction chain-slat design only needs a single drive, resulting in substantial savings in energy, controls and systems integration.

Finishes: Ryson Spirals are available in powder coated carbon steel, stainless steel wet, hybrid and freezer versions, providing the most economical solution to the operating environment.

Overlapping Slats:

Overlapping slats provide a smooth and efficient conveying surface, ensuring gentle product handling and suitable for all types of conveyable items.



Proprietary Belt Slat:

Our innovative chain-slat design enables a low friction operation without any sliding movements or wear-strips. This allows the Spiral to stop and start fully loaded.



Controls and Integration: Most Spirals are shipped without controls because they typically integrate with an overall conveyor control system. We do offer a number of controls and pre-wiring options. A Variable Frequency Drive (VFD) is required for proper operation of the spirals.



Scan or Click
for full details



Quick Facts:

Top Speed: 200 FPM*
 Max Height: 45"
 Slat Width: 6" - 36"
 Weight Capacity: 50 lbs/lin foot**
 Total Weight: Up to 1800 lbs**
 VFD Required: Yes
 Optional Controls: Yes
 Custom Options: Yes
 Color Options: RAL colors
 Incline Angle: Up to 12.5°

* Depending on model

** For Standard Capacity, high capacity is double

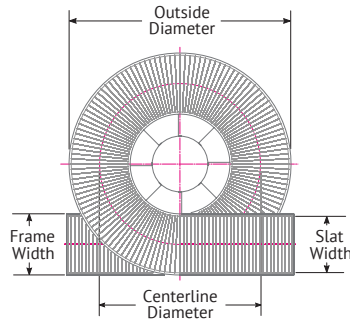

Configurations:

All Ryson Spiral Conveyors are available in several standard versions to accommodate a wide range of loads and applications.

- The Spiral Conveyors can be configured to go up or down, clockwise or counter-clockwise and can optionally be reversible.
- All models can be built with extended infeed or outfeed tangents, making our Spiral Conveyors an easy to fit and help simplify the most challenging of layouts.

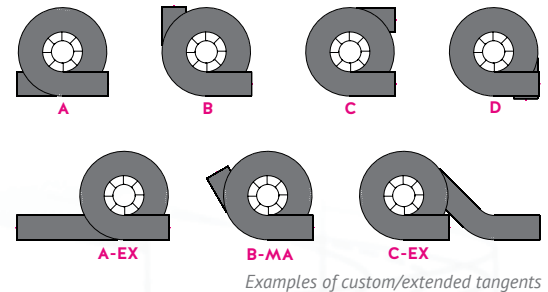

Type	Outside Diameter	Centerline Diameter	Slat Width	Frame Width
1200-300	5'-3" (1600)	3'-11" (1200)	12" (300)	15" (380)
1300-400	5'-11" (1800)	4'-3" (1300)	16" (400)	19" (480)
1500-400	6'-7" (2200)	4'-11" (1500)	16" (400)	19" (480)
1800-400	7'-7" (2300)	5'-11" (1800)	16" (400)	19" (480)
1600-500	7'-3" (2200)	5'-3" (1600)	20" (500)	23" (590)
1800-650	8'-6" (2600)	5'-11" (1800)	26" (650)	29" (740)

Check out our Narrow Trak, Wide Track and Mass Flow models for additional size information

Typically Conveys:



Cartons



Carton wrapped



Bags



Crates



Trays



Totes



Shrink wrapped



Jugs



Pails



Bundles

Powder Coated Carbon Steel

Part	Specifications
Frame	Coated aluminium tube with galvanized load arms
Chain configuration	Nickel plated chain, carbon steel bearings
Finish	Powder Coated in most RAL colors

Stainless Steel Hybrid (Dry)

Part	Specifications
Frame	Coated aluminium center tube zinc plated load arms
Chain configuration	Nickel plated chain, carbon steel bearings
Finish	Stainless steel base frame, legs & side guards.

Stainless Steel (Wet)

Part	Specifications
Frame	Stainless steel or coated aluminium tube depending on model. Stainless steel base frame, load arms & fasteners.
Chain configuration	Nickel plated chain with stainless steel sealed bearings
Finish	Stainless steel base frame, legs & side guards.



VERTICAL CONVEYING SOLUTIONS. WORLDWIDE.

Ryson is a member of the Royal Apollo Group, established in 1847 and headquartered in the Netherlands. Ryson manufactures in USA and supports North America. We have manufacturing in Netherlands, USA, and Thailand with service operations in Netherlands, USA, Thailand, China, India, and Mexico. As one global company, we are the world's leader in Vertical Conveying!

