

Request for Quotation

Fax to: (757) 898-1580

Company: _____

Date: _____

Address: _____

Phone: _____

Requested by: _____

Fax: _____

E-mail: _____

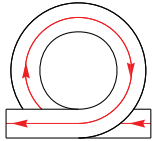

Type A-1
Elevate
Clockwise

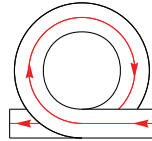

Type A-2
Descend
Clockwise

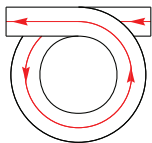

Type A-3
Elevate
Counter-
Clockwise

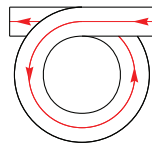

Type A-4
Descend
Counter-
Clockwise

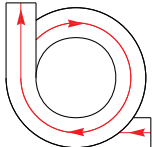

Type B-1
Elevate
Clockwise

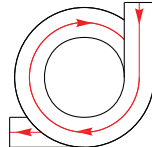

Type B-2
Descend
Clockwise

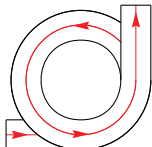

Type B-3
Elevate
Counter-
Clockwise

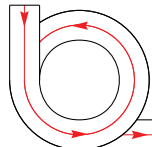

Type B-4
Descend
Counter-
Clockwise

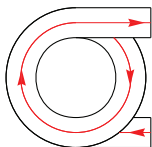

Type C-1
Elevate
Clockwise

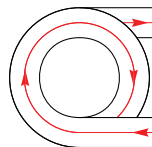

Type C-2
Descend
Clockwise

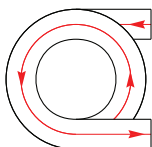

Type C-3
Elevate
Counter-
Clockwise

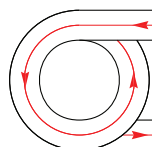

Type C-4
Descend
Counter-
Clockwise

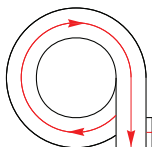

Type D-1
Elevate
Clockwise

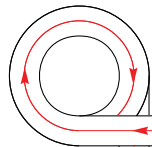

Type D-2
Descend
Clockwise

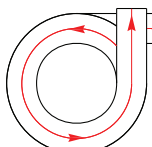

Type D-3
Elevate
Counter-
Clockwise

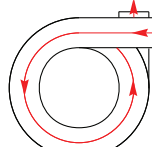

Type D-4
Descend
Counter-
Clockwise

Product to be Handled: _____

Length: _____ Min. _____ Max.

Width: _____ Min. _____ Max.

Height: _____ Min. _____ Max.

Weight: _____ Min. _____ Max.

Flaps: Open Closed

Infeed Height: _____

Outfeed Height: _____

Elevation Change: _____

Direction: Up Down

Type/Model: _____

Products/Minute: _____

Conveyor Speed: _____

Power Supply: _____

Width (BF) of Infeed Conveyor: _____

Width (BF) of Outfeed Conveyor: _____

Finish/Color: _____

Special Requests: _____

Ryson Spiral Model Naming Key

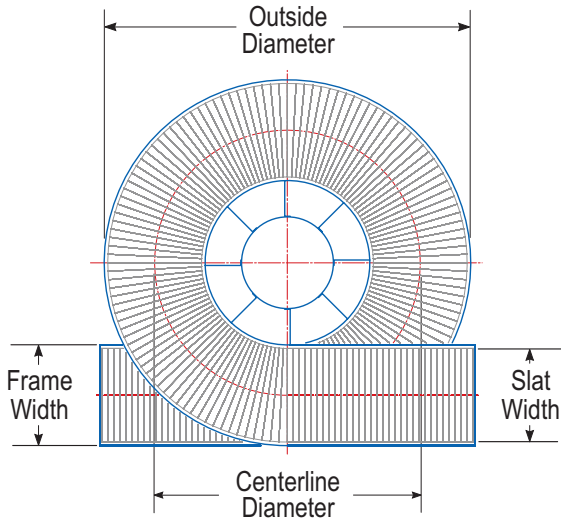

- 1 Elevate Clockwise
- 2 Descend Clockwise
- 3 Elevate Counter Clockwise
- 4 Descend Counter Clockwise

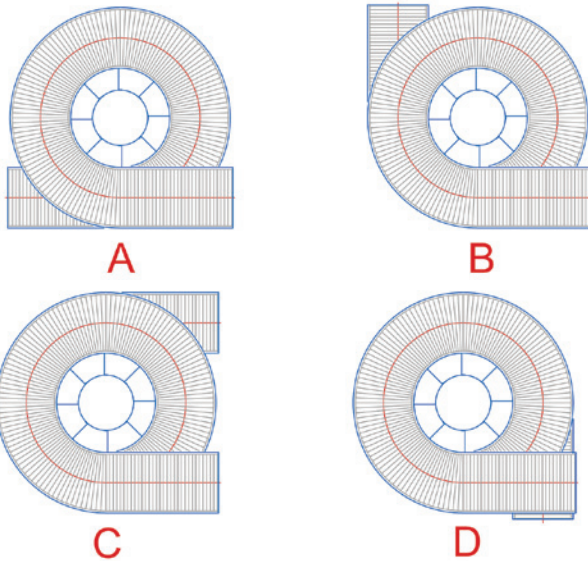

Type	Outside	Centerline	Slat	Frame
1200-200	4'-9" (1450)	3'-11" (1200)	8" (200)	11" (280)
1600-200	6'-3" (1900)	5'-3" (1600)	8" (200)	11" (280)
1200-300	5'-3" (1600)	3'-11" (1200)	12" (300)	1'-3" (380)
1300-400	5'-11" (1800)	4'-3" (1300)	16" (400)	1'-7" (480)
1500-400	6'-7" (2200)	4'-11" (1500)	16" (400)	1'-7" (480)
1800-400	7'-7" (2300)	5'-11" (1800)	16" (400)	1'-7" (480)
1600-500	7'-3" (2200)	5'-3" (1600)	20" (500)	1'-11" (590)
1700-600	7'-11" (2400)	5'-7" (1700)	24" (600)	2'-3" (680)
1800-650	8'-6" (2600)	5'-11" (1800)	26" (650)	2'-5" (740)
High Capacity				
1700-400-HC	7'-3" (2200)	5'-7" (1700)	16" (400)	1'-7" (480)
1700-600-HC	7'-11" (2400)	5'-7" (1700)	24" (600)	2'-3" (680)
Mass Flow				
1900-300	7'-7" (2300)	6'-3" (1900)	12" (300)	-
1900-400	7'-11" (2400)	6'-3" (1900)	16" (400)	-
2300-500	9'-6" (2900)	7'-7" (2300)	20" (500)	-
Dual Track				
1200-200/1800-200	6'-11" (2100)	5'-11" (1800)	8" (200)	-
1200-300/2000-300	7'-11" (2400)	6'-6" (2000)	12" (300)	-
1300-400/2300-400	9'-3" (2800)	7'-7" (2300)	16" (400)	-
1600-500/2800-500	11'-2" (3400)	9'-2" (2800)	20" (500)	-

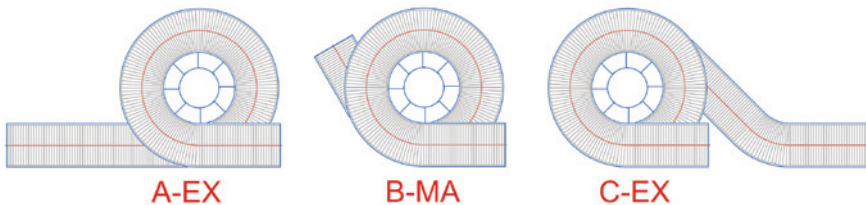

The position and length of the in feed tangent on up spirals and out feed tangent on down spirals can be customized to meet specific layout requirements. Samples are shown above.

NOTE: CAD blocks use metric units. They need to be scaled 1/25.4 for inches.



www.ryson.com